

ONWA[®]
KV-300

KV-300
OPERATOR'S MANUAL

VHF DSC MARINE TRANSCEIVER

CONTENTS

1. ABOVE ALL... SAFETY!	1
1.1 Symbols used.....	1
1.2 Warnings.....	1
1.2.1 General.....	1
1.2.2 Radio Frequency/Installation.....	1
1.2.3 Automatic Transmitter Identification System (ATIS).....	2
1.2.4 Environmental.....	2
1.3 ETSI Information.....	2
1.4 Assistance.....	2
1.5 Manual Notes.....	2
2. INTRODUCTION	3
2.1 Generalities.....	3
3. DESCRIPTION OF CONTROLS AND CONNECTORS	4
3.1 Front panel.....	4
3.2 Back panel (connections).....	6
3.3 Microphone.....	6
4. INSTALLATION	7
4.1 Contents of package.....	7
4.2 Location for the transceiver.....	8
4.3 Mounting of transceiver.....	8
4.4 Adjustment of angle.....	9
4.5 Installation of the antenna/electromagnetic exposure.....	9
4.6 Mounting of Microphone.....	9
4.7 Connections.....	10
4.7.1 Power Supply.....	10
4.7.2 GPS device.....	10
4.7.3 Antenna.....	10
5. BASIC OPERATION	11
5.1 Turning KV-300 on/off.....	11
5.2 Volume adjustment.....	11
5.3 Squelch Regulation.....	11
5.4 Selecting an operating channel.....	11
5.5 Transmission and reception.....	12
5.6 Selecting high and low transmission power.....	12
5.7 Instant recall of channel 16.....	12
5.8 Display/keypad lighting.....	12
6 . SCANNING FUNCTIONS	13
6.1 Channel scanning.....	13
6.2 Dual Watch and Triple Watch.....	14
6.3 MEM function.....	14

7. USE WITH GPS	15
7.1 Function.....	15
7.2 GPS information on the display.....	15
8. DIGITAL SELECTIVE CALLING (DSC)	16
8.1 Introduction.....	16
8.2 Mobile Marine Identification Service (MMSI).....	16
8.3 Navigating the DSC menu.....	16
8.4 Sending Individual call (ROUTINE TO).....	17
8.5 Sending Group calling (Group Call).....	17
8.6 Sending General call to all ships (ALL SHIP SAFETY - ALL SHIP URGENCY).....	18
8.7. Sending DSC DISTRESS call.....	18
8.7.1 Sending a DISTRESS call.....	18
8.8 Position request.....	19
8.9 Stand By option.....	20
9. RECEIVING A DSC CAL	21
9.1 Receiving a Individual Call.....	21
9.2 Receiving a Group Call.....	21
9.3 Receiving a General call to all ships(ALL SHIP SAFETY- ALL SHIP URGENCY).....	22
9.4 Receiving a DSC Distress call.....	22
10. CUSTOMIZATION	23
10.1 Log (list of registered calls).....	23
10.2 Dir” (Entries in the directory).....	23
10.3 GPS.....	24
10.4 GPS select.....	24
10.5 "Beep" (Enable/disable keypad beep).....	25
10.6 Display/keypad backlight.....	25
10.7 Band edit.....	25
10.8 LCD contrast.....	26
10.9 MMSI (Setting of personel MMSI code and MMSI group code).....	26
10.10 "ATIS" (Setting of ATIS code and activation - deactivation of automatical transmission).....	27
11. PROGRAMING AND SELECTION OF PRIVATE CHANNELS	28
12. MAINTENANCE	29
12.1 Maintenance and warnings.....	29
13. TROUBLESHOOTING	30
14. TECHNICAL SPECIFICATIONS:	31
14.1 Transmitter.....	31
14.2 Receiver.....	31
14.3 70 Channel receiver.....	32
14.2 GPS.....	32
15. FREQUENCY TABLE	33

1. ABOVE ALL... SAFETY!

1.1 Symbols used

For ease and convenience of viewing, KV-300 uses symbols to highlight urgent situations, practical advice, and general information.

****Warnings such as this, shown using an open hand symbol, indicate a crucial description regarding technical repairs, dangerous conditions, safety warnings, advice and/or important information. Ignoring these symbols may result in serious problems and/or damage and/or personal injury.***

Notes: such as this one indicate practical advice that we suggest be followed for optimal performance with KV-300.

1.2 Warnings

1.2.1 General

- This device has been tested for compliance with Class D digital marine device limits. These limits were created to allow for reasonable protection against damaging interference.
- This device is to be used solely as an aid to navigation. Its settings may be influenced by diverse factors, such as defects or malfunction of the device, environmental conditions or improper use.
- It is the user's responsibility to observe reasonable prudence and judgement in navigation, and as such this device should not be considered a substitute for this reasonable prudence and judgement.
- Do not open the radio for any reason! KV-300's precision mechanics and electronics require expertise and specialized equipment; for the same reason, the radio should under no circumstances be realigned as it has already been calibrated for maximum performance. Unauthorized opening of the transceiver will nullify the warranty.

1.2.2 Radio Frequency/Installation

- Midland recommends following the requirements for prevention of radiofrequency exposure. Unauthorized changes or modifications to this device may invalidate conformity to the ETSI Regulations.
- This VHF DSC transceiver generates and irradiates electromagnetic energy (EME) at radiofrequency (RF), and as such must be installed and placed in operating conditions that are in conformity with the instructions contained in this manual and with current regulations. Not following these instructions can cause personal injury and/or malfunction of the device.
- Do not use KV-300 before connecting a suitable antenna that is in perfect working condition although KV-300 is protected, this may seriously damage the stages of transmission power.
- Do not use transmit before ensuring proper connection of the antenna. During transmission, remain at a minimum distance of 1m from the antenna.

Warning:

- User may hold the PTT five minutes, but the device should be placed in inaccessible areas to avoid burns others.
- Long-Time emission may shorten the life of the equipment.

1.2.3 Automatic Transmitter Identification System (ATIS)

- Your marine transceiver may activate, if necessary, the ATIS function. The ATIS function may be activated when using the transceiver within the internal navigable waters of Europe which require the automatic transmission of identification. For further details, please contact your local authorities.

1.2.4 Environmental

- Pay attention to ambient conditions although KV-300 is designed to operate under the most severe conditions, it is important to avoid exposure to environments that are excessively humid or dusty, or to temperatures outside the 15 to +55°C range. Also avoid exposure to direct sunlight.
- Avoid jarring and excessive vibration KV-300 is built to resist mechanical shock and vibration as long as these are within the norm for any electrical device.
- Do not use this device in potentially explosive environments. A single spark may cause an explosion.

1.3 ETSI Information

ETSI (European Telecommunications Standards Institute) has established specific requirements (EN 301 025-2/3) for marine transceivers with DSC function class For use on non-SOLAS vessels.

1.4 Assistance

We urge you to write the serial number of your transceiver in the space provided below. This number is found on the back panel of the transceiver and will be useful in the event of repair/assistance and/or loss and/or theft..

1.5 Manual Notes

Writing of this manual has been completed with the intention of supplying information that are comprehensive, precise and up-to-date. Nevertheless, the manufacturer does not assume responsibility for the actual correspondence with the product and for the consequences of possible errors caused by factors over which it has no control. Equipment and options described may differ according to varying countries.

2. INTRODUCTION

2.1 Generalities

Congratulations for choosing ONWA's marine transceiver KV-300. This product is a high performance, mobile VHF DSC marine transceiver. The following are its principle features:

- **Equipped with all international channels** available (correctly assigned).
- **High transmission power of 25W**, which allows the user to maintain contact from large distances, and a low transmission power of 1W to reduce consumption during short-distance communication.
- **Principal commands duplicated on the microphone** for faster accessibility – channel selection and channel 16 recall.
- **Back lit LCD display and adjustable contrast** – constantly shows KV-300's parameters and settings and occurs an optimal visualization.
- **Possibility to program 20 private channels** by means of the optional programming kit " PRG KV-300 ". We remind that the use of private channel is controlled by the national competent authorities: for this reason, we suggest you contact the local radio communication authorities.
- **Extraordinary capability for water resistance**, conforms to the with Japanese Industry Standard level JS7 or IPX7.
- **Recall button for Channel 16** – for instant access to channel 16 (the universal marine channel for emergency contact).
- **NMEA connection** – use the interface cable supplied for easy connection from transceiver to optional GPS system, such as KP-32 or other compatible GPS. Once connected, the display will show the automatically updated coordinates (latitude and longitude) and time data.
- **DSC Digital Selective Calling** – for security on the water and the ability to make quick calls automatically (the transceiver supports DSC (Digital Selective Calling) operations with a specifically designed DSC unit which conforms to the ITU-R standard, M493-11 Class D requirement).
- **MMSI directory**, which simplifies the sending of DSC calls to frequently called contacts and allows viewing of contact name on the display.
- **Mounting on adjustable bracket** for stable and comfortable positioning in any condition.
- **Connection to an external speaker** (optional) – for listening to communications further away from the transceiver.

3. DESCRIPTION OF CONTROLS AND CONNECTORS

3.1 Front panel

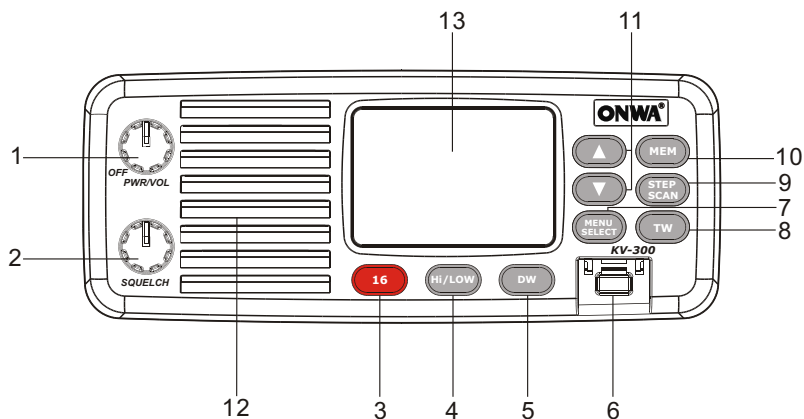



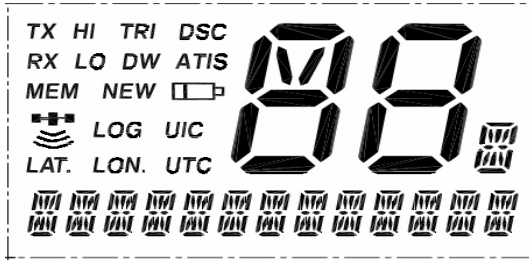

1. **PWR/VOL** - Turns KV-300 on/off and regulates audio volume reception.
2. **SQUELCH knob** - Regulates the squelch level (noise silencer in absence of signals).
3. **Button 16** - Pressing the 16 button provides quick access to channel 16.
4. **Hi/LOW** - To select the high or low transmission power.
5. **DW button** - This button activates the Dual Watch function, able to monitor two channels of your choice.
6. **DISTRESS button** - The button below a soft cover sends a DISTRESS call for help. The signal also includes your MMSI identification code and the nature of the distress. If a GPS is connected to the device, data regarding position and time are also included in the call.
*** The Distress function, or any other DSC transmission function, is not operative until a MMSI user code has been inserted.**
7. **MENU/SELECT** - To enter the menu of the radio and confirm the selected settings.
8. **T/W button** - Activates the Triple Watch function, able to monitor 3 different channels.
9. **STEP/SCAN button** - To select two different types of scanning.
10. **MEM button** - Allows to store the selected channel and insert it in the memory group.
11. **UP/DOWN controls** \wedge/\vee - They are useful to look through the menu and to select the channels.
12. **Internal speaker** - Guarantees clear listening of communications.

13. LCD Symbols and Meanings:



This simulation shows the locations of all the following information symbols:

Symbol Meaning

TX	Transmitting
HI	LOTransmission power.(HI)25W or LOW(LO) 1W
RX	Receiver Busy with an incoming singal
TRI	Triple Watch function
DW	Dual Watch function
DSC	DSC capability is available
ATIS	KV300(EU only),and enabled for radio in European inland waterways.
MEM	Memory
NEW	New address
	Low Battery warning (activates at 10.5v)
	GPS receiver icon
LOG	List of registered calls
UIC	Selected channel band(USA-INT-CAN) for VHF radio operations and regulation
LAT.	Latitude
LON.	Longitude
UTC	Universal Time Coordinated
	Channel Suffix if applicable
	Channel Selected

A type operational display is shown here.



The latitude and longitude of the vessel and the local time are shown.

Indicate: LAT.99° 99 LON.999° 99 .88:88. Etc...

3.2 Back panel (connections)

*** Warning! Faulty connections or short-circuits may seriously damage KV-300. Before attempting any connections, consult the specialized sections of this manual.**

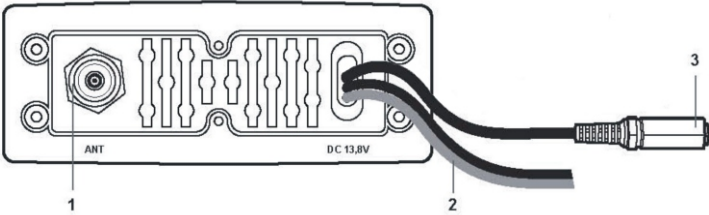

1. Antenna socket

This SO 239 socket is for connecting an appropriate antenna.

2. Power cable

This red/black cable has to be connected to a power source of 12 Vdc (red is positive).

3. Socket for additional external loudspeaker/GPS Connection

You can use this jack for the connection to a suitable external loudspeaker (optional), if needed.

Allows for connection to the optional GPS module “KP32” (or other compatible Receiver Module), for obtaining, viewing and transmitting (with DSC) information regarding position and current time data.

3.3 Microphone

1. **UP and DOWN buttons:** These two buttons change the tuning channel. The first scrolls upwards through the tuned marine channels, the second scrolls downwards.
2. **Button 16:** For ease of use, button 16 performs the same function as the button 16 on the front panel of the transceiver.
3. **MENU:** activates the same functions/features of the MENU button on the front panel of the radio.
4. **PTT (push to talk):** Pressing this button will begin transmission
5. **Microphone:** During transmission, speak a few centimetres from the microphone.

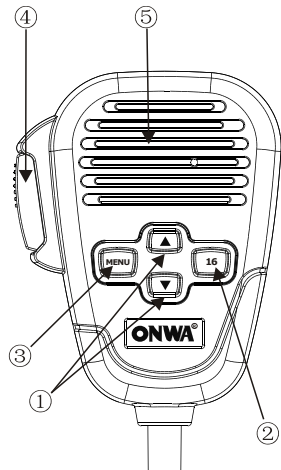

4. INSTALLATION

4.1 Contents of package

Before using your transceiver, ensure that your package is complete and contains:

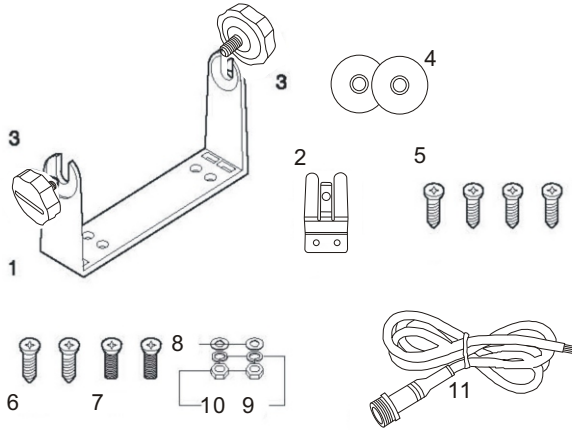

1. Mounting bracket
2. Mounting pieces for microphone
3. Knobs (2 pieces)
4. Circular film (2 pieces)
5. Self-threading screws for mounting bracket (4 pieces)
6. Screws for the microphone mount (2 pieces)
7. Screws for mounting bracket (2 pieces)
8. Washers (2 pieces)
9. Spring Washers (2 pieces)
10. NUTS (2 pieces)
11. 5Pin Cable for GPS Receiver and external loudspeaker
 - Black: GND
 - Red: 5V
 - Yellow: SPEAKER
 - Green: NMEA0183 IN+
 - Blue: NMEA0183 IN-

* Depending on the model, some parts may already be attached/connected to the device.
In any case, if any parts are missing, immediately contact your supplier.

4.2 Location for the transceiver

Before continuing, look for a place to install the transceiver which:

- Is far enough away from any device sensitive to magnetic/electromagnetic fields (e.g. compass) in order to avoid interference during their use.
- Allows for accessibility to the front panel of KV-300.
- Provides easy connection to a power supply, for the antenna and for other cables.
- Has sufficient space close by for installation of the microphone support.
- Allows for mounting of the antenna at least 1 meter from the transceiver.

The universal mounting bracket supplied allows for mounting of the transceiver high up (with the bracket above the device) or on the bridge (with the bracket below the device) with an angle range of 45°.

- * **Warning! Installation and connections must be performed in part by qualified persons.**

4.3 Mounting of transceiver

To mount the transceiver to your vessel (see following picture):

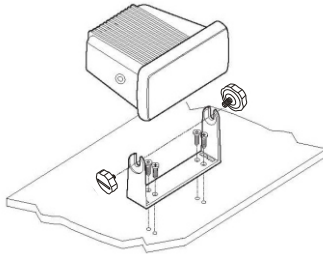

1. Choose an appropriate location, as explained in the paragraph above.
2. Position the mounting bracket on the surface upon which it will be fixed, use a pencil to draw the position of the four holes where the screws will be inserted.
- * **Ensure that the surface intended for the transceiver mounting can be drilled into without provoking damage to other parts of the vessel and be careful to not drill right through it.**
3. Remove the bracket, drill four holes smaller in diameter than the screws, and reposition the mounting bracket, aligning it with the four holes.
4. Screw in the mounting screws and ensure the bracket is fixed firmly, using the screws, the Spring washers, the flat washers and the nuts supplied.
If you are not able to reach the back part of the bracket surface to fix the nuts onto the screws, use threaded screws to fix the bracket.
5. Tighten the screws with a screwdriver so that the bracket is firmly fixed to the surface.

- Align the transceiver on the bracket, ensuring the holes of the internal part of the bracket line up with those on both sides of the transceiver (you can choose the preferred notch in order to best adjust the angle of the transceivers front panel for ease of viewing and use (15° of variation for each notch).
- Mount the mounting knobs on the two sides of the bracket to soundly fix the transceiver. **Keep the transceiver and microphone at a distance of at least 1 meter from all other magnetic devices (e.g. compass) on your vessel.**

4.4 Adjustment of angle

To change the angle of inclination after installation:

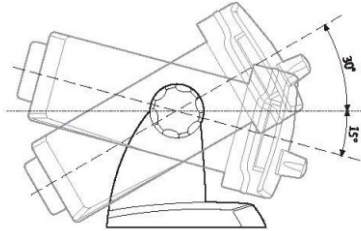

- Loosen the mounting knobs on the sides of the bracket.
- Adjust the transceiver to a better angle, lining up the holes of the internal part of the bracket with those on both sides of the transceiver.
- Tighten the knobs to fix the transceiver into place.

4.5 Installation of the antenna/electromagnetic exposure

For optimal radio settings and minimal user exposure to electromagnetic radiofrequency energy, ensure that:

The antenna is connected to the transceiver and is properly installed.

The antenna is situated away from people and is positioned at least one meter from the transceiver and microphone.

The connector is a standard PL259 (male UHF).

4.6 Mounting of Microphone

To mount the microphone mount, look first for a mounting point close to the transceiver. The distance between the transceiver and the wall mount must be less than the length of the microphone cable.

Do not pull excessively on the microphone cord. This part is important to the correct function of the device: over time, pulling may damage the cord and impede the user from transmitting.

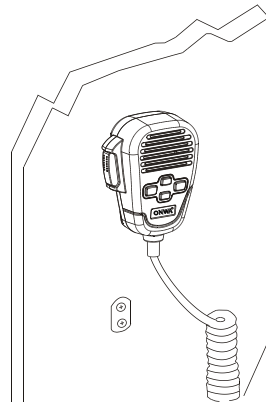

4.7 Connections

Refer to the following diagram:

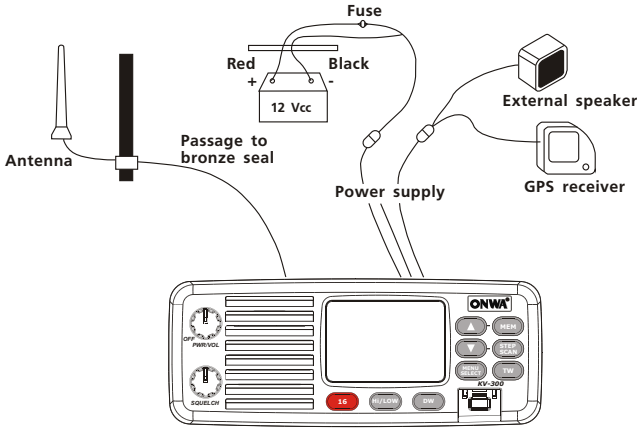

4.7.1 Power Supply

The transceiver power supply must be 12Vdc. The red cable must be connected to the positive pin, the black to the negative pin.

Warning! A faulty connection may seriously damage the radio!!

The power cable is equipped with a protection fuse. If the fuse shorts, look for its reason before substituting the cable with a new one of the same type and value. Never short circuit it, as this may damage the radio. We suggest using the supplied cable.

4.7.2 GPS device

If your KV-300 transceiver is connected to a GPS receiver Module, such as the KP32, you can obtain and view NMEA information relative to the current position the vessel (latitude and longitude) and the local time with respect to Greenwich Mean Time (GMT).

4.7.3 Antenna

The antenna is an extremely important part of the device and noticeably influences the settings of any telecommunications device. Contact your supplier regarding the antenna and request advice about how to mount and best connect it to your transceiver.

Warning! *Ensure the antenna is in perfect working order. It may otherwise seriously damage the radio! A periodical measurement of the stationary waves is advised using a suitable SWR metre.*

5. BASIC OPERATION

5.1 Turning KV-300 on/off

To turn the transceiver on, rotate the **PWR/VOL** knob clockwise until it clicks on. You will hear a beep(acoustic signal)and the LCD display will show the channel in use.

Important: when you turn on the radio for the very first time, the display will show channel 16; while usually, **KV-300** stores the last channel in use before it's switched off. To turn the transceiver off, rotate the knob counter-clockwise until you hear a click.

5.2 Volume adjustment

Bring the **OFF/VOLUME** knob first to medium volume.Once the transceiver picks up a signal, adjust the volume t o a comfortable level. If no signal is picked up, use the squelch control as described in the following paragraph and regulate the volume using the background noise.

5.3 Squelch Regulation

Squelch is used to eliminate the annoying background noise you hear when no signal is being picked up. If the squelch is adjusted correctly, there should be silence in between calls as well as a reduction in battery consumption. To regulate the squelch:

1. Rotate the **SQUELCH** knob completely counter-clockwise until you hear the background noise (if you don't hear anything, increase the volume); **RX** will appear on the display.
2. If no signal is being received (only noise), slowly rotate the **SQUELCH** knob clockwise, stopping as soon as the noise and **RX** disappear stably.

If you regulate the squelch level too high (closed), you may hear only background noise or intermittent discharges.

5.4 Selecting an operating channel

Press repeatedly the **UP** or **DOWN** buttons on the keypad or on the microphone to scroll through the marine channels until finding the desired channel.

Channel 16 is dedicated to the emergencies, therefore we recommend not to use it for general communications!

Channel 70 is dedicated to DSC communications.

5.5 Transmission and reception

Transmitting without a perfectly functioning antenna may seriously damage the transceiver.

The PTT (Push-To-Talk) button is located on the external microphone of your KV-300. To transmit:

1. Ensure that no one else is speaking.
2. Hold down the PTT button on the microphone. TX will appear on the Display. Wait for a second, then speak in a normal voice about 5 cm from the microphone.
3. When you have finished, release the PTT button: TX will disappear from the display. Now KV-300 is in receiving mode (silent and waiting for a signal) and will automatically receive any communication.

5.6 Selecting high and low transmission power

The transmission phase absorbs the most energy. To reduce the risk of wearing out the battery, we recommend selecting low transmission power when transmitting over short distances. Hold the H/L button down (on the radio): **Lo** (low power) appears on the display. When transmitting or receiving over long distances or with weak signals, press the H/L button again. **Lo** will be replaced with **Hi** (high power) on the display.

When the transceiver is tuned to a channel limited to low output power, pressing the H/L button has no effect.

5.7 Instant recall of channel 16

Channel 16 is a security and distress channel. This channel is used for emergency communications.

Press the 16 button (the red one on the keypad) and you will be tuned on the emergency channel.

To return to the channel previously used, simply press the 16 button again.

Do not transmit on channel 16 unless absolutely necessary. Doing so may impede emergency operations.

5.8 Display/keypad backlight

The display/keypad backlight can be adjusted according to your needs or to the environmental conditions.

To select the desired level of backlight:

- Keep pressed MENU/SELECT until DSC CALL appears on the display;
- Using the UP/DOWN buttons select SYSTEM and confirm pushing MENU/SELECT;
- Select BACKLIGHT and confirm by pushing MENU/SELECT;
- Select the desired backlight level, from 0 to 3.

To return to the radio modality, push PTT, select EXIT in every menu, or wait for 1 minute and the radio will automatically exit.

6. SCANNING FUNCTIONS

6.1 Channel scanning

KV-300 can automatically search for signals throughout the marine band by scanning, or selecting the channels in rapid sequence. When a signal is detected, the scanning pauses on that channel (**RX** displayed) and remains blocked until the signal ends. Before the scanning automatically starts again, **KV-300** waits for a 3,4 seconds in case the user wants to transmit.

You can transmit in any moment, even if the scanning is active. In this case, the transmission will be done on the channel currently scanned; but if you transmit just after a signal is detected, the radio will transmit on that channel.

After the transmission, the scanning is interrupted.

If the scanning detects an undesired channel, you can start scanning again by pushing **STEP/SCAN**.

To activate the Scan function:

- Hold down the **STEP/SCAN** button till **scan** on the display;
- Press **MENU/SELECT** to confirm your selection. The scanning will start.
- To stop the **SCAN**, then press the **STEP/SCAN** button.

The scanning and the memory scanning cannot properly work if the squelch is not adjusted as previously described.

To activate the Mem Scan function:

- Pressed **STEP/SCAN** till **MEM** appears on the display;
- **MEM** scanning will start.(Now the scanning of the stored channels starts.)
- To stop it, push **STEP/SCAN** and the radio will stop on the channel scanned in that moment.
- **Reception:** if **KV-300** detects a signal, the scanning interrupts and the display indicates "**RX**".
- **Transmission:** you can transmit in any moment,even if the scanning is active. In this case, **KV-300** will transmit from the channel being scanned in that moment; but if the transmission is done after a channel is picked up, the device will transmit from that channel within 3 / 4 seconds. After the transmission, the scanning interrupts.

6.2 Dual Watch and Triple Watch

Dual Watch

Allows you to monitor two channels at the same time: the channel in use and channel 16 (emergency channel).

- With the UP/ DOWN keys to choose the right channel
- To activate this function, push **DW** and the radio will start monitoring both channels.

To disable this function push **DW** again and the radio will return to the channel in use.

If you push **PTT** the scanning will stop and the radio will go to channel 16.

The Dual Watch and Triple Watch stop when a signal is picked up, giving you the possibility to answer.

These functions cannot operate properly if the squelch is not adjusted.

Triple Watch

This function allows the monitoring of three channels at the same time: channel 16, channel in use and one channel of your choice.

Procedure:

- Press **T/W**, until " **TRIPLE WATCH** " blinks on the display;
- Select the second channel you want to monitor; CH16 is automatically monitored;
- Confirm by pushing **T/W** again; the scanning of the 3 channels will begin.

To stop it, press **T/W** and the radio will automatically return to the second channel selected.

If you push **PTT** the scanning will stop and the radio will go to channel 16.

The Dual Watch and Triple Watch stop when a signal is picked up, giving you the possibility to answer.

These functions cannot operate properly if the squelch is not adjusted.

6.3 MEM function

This function allows you to store some channels to scan through the Mem Scan function. To store a channel, follow these steps:

- Select the channel to store: keep pressed the **MEM** button till the display shows **mem**.
- Repeat the same procedure to store other channels.

To delete a pre-selected channel in memory:

- Select it and keep pressed **MEM** button till **mem** disappears from the display.

The other stored channels can be easily monitored through the MEM SCAN function.

The MEM SCAN function cannot properly work if the squelch is not correctly adjusted

7. USE WITH GPS

7.1 Function

- If connected to a GPS receiver Module (KP32), the transceiver will display the vessel position (latitude and longitude), as well as time data.
- If the information regarding position data are not received in the normal radio mode and the time data does not appear within 4 hours, a 30-second-long warning tone will sound (can be deactivated by pressing any button).

The display will show " **POSITION IS OVER 4 HOURS OLD** " .

You may also insert the coordinates manually.

7.2 GPS information on the display

Once connected the GPS (KP32) to your KV-300 (PS 2 connector), the symbol “” will the Lcd display till your position will be established.

Then, the radio display will show theGPS coordinates and the time data.

8. DIGITAL SELECTIVE CALLING (DSC)

8.1 Introduction

Digital Selective Calling is a semiautomatic method for controlling VHF, MF and HF radio calls. **It was also designed as part of the Global Marine Distress and Safety system(GMDSS).** It is likely that DSC will eventually replace audio calls on emergency frequencies and will be used to send urgent and routine radio-transmitted maritime security information. This new service will allow crafts to send/receive calls of an emergency, urgent, security, or routine nature to/from vessels equipped with a DSC transceiver.

To avoid accidentally sending a distress call or a call sent incorrectly, contact your vendor or local authorities for updates on DSC operating and emergency procedures.

8.2 Mobile Marine Identification Service (MMSI)

Important! To send/receive DSC calls, the user must program his personal MMSI code into the transceiver. This is a nine-digit number used by marine transceivers equipped for DSC digital selective calling. This number is used much like a telephone number for contacting other, specific vessels.

DSC transmissions can be done only if you have been assigned the individual MMSI code and you entered it in your radio(otherwise the Distress/DSC controls will be disabled).

Sending a distress call without founded reason is a criminal offence. Never use this function unless you find yourself in a situation that merits asking for help.

8.3 Navigating the DSC menu

KV-300 offers many DSC function .For this reason it was created.

Once inside a sub-menu, you can return at any time to the main menu by pressing the PTT button.

To return to the radio mode, confirm EXIT in every menu.

8.4 Sending Individual call (ROUTINE TO)

The user can carry out an individual call to a specific DSC station (a vessel or a coastal station).

To carry out calls, you have to enter the MMSI code manually or recall it from the preprogrammed MMSI directory.

- Keep pressed MENU/SELECT till DSC CALL is displayed;
- Confirm your selection by pushing MENU/SELECT; the display will show INDIVIDUAL. Push MENU/SELECT again for confirmation;
Now you can choose whether inserting the MMSI code manually or recall it from the directory previously set
- Scroll with the UP/DOWN keys the 9 digits composing the code;
- Confirm by pushing MENU/SELECT;
- With the UP/DOWN keys select one of the 23 channels available (simplex) and confirm your selection with MENU/SELECT. Display will jump to the selected channel interface, the following shows the "SEL SEND CH"
- Confirm by pushing MENU/SELECT, The transmission is sent and WAITING ACK will on the display;
- if your call is confirmed by the other party, the display shows his name " INDIVIDUAL ROUTINE FROM MMSI ON CHANNEL 6 (OTP) " and you will hear a beep.
- If you push MENU/SELECT the display indicates the channel previously selected and the beep will stop; instead if you push any other channel, you will exit the individual call.

8.5 Sending Group calling (Group Call)

This function allows the user to call a specific group of stations which have the same MMSI group code stored in their transceivers and which signals the audio channel the user wishes to speak on.

Therefore you can only carry out the group call when you have programmed the addresses in a directory.

- Keep pressed MENU/SELECT till DSC CALL is displayed;
- Confirm by pushing MENU/SELECT; INDIVIDUAL will appear on the display;
- Scroll through the channels with the UP/DOWN keys;
- Select GROUP and confirm the selection with the MENU/SELECT button;
- You will be asked the code previously set; after this selection, confirm by pushing MENU/SELECT;
- Select one of the 23 channels available, send the call and press MENU/SELECT as confirmation.

8.6 Sending a call to all ships

(ALL SHIP SAFETY - ALL SHIP URGENCY)

- Keep pressed MENU/SELECT till DSC CALL is displayed;
- Confirm by pushing MENU/SELECT;
- Scroll through the channels with the UP/DOWN keys;
- Select ALL SHIP and push MENU/SELECT as confirmation;
- Select ALL SHIP SAFETY with the UP/DOWN keys and push MENU/SELECT;
- Select the desired channel and send the call by pushing MENU/SELECT;
- To send an ALL SHIP URGENCY call, repeat the above described procedure except the channel selection which is not required (the DSC is automatically sent to channel 16).
- Sending a distress call without founded reason is a criminal offence.
Never use this function unless you find yourself in a situation that merits requiring help.

8.7 Sending DSC DISTRESS call

8.7.1 Sending a DISTRESS call

IMPORTANT! You can only send a DSC call if you have been assigned an individual MMSI code and this code has been programmed into the transceiver (otherwise the following commands will be deactivated).

Sending a distress call without founded reason is a criminal offence.

Never use this function unless you find yourself in a situation that merits requiring help.

The **DISTRESS** button is protected by a small plastic shutter.

This button activates preset emergency messages which are transmitted on a dedicated channel, channel 70. These messages are sent to all the radios operating within your range and may be sent also to a busy channel.

To activate a Distress call: raise the shutter, press **DISTRESS** and choose, with the UP/DOWN keys, the desired message amongst these:

- A. UNDEFINED
- B. ABANDONING
- C. PIRACY
- D. M.O.B. (man over board)
- E. FIRE
- F. FLOODING
- G. COLLISION
- H. GROUNDING
- I. LISTING
- L. SINKING
- M. ADRIFT
- N. EPIRB EMISSION

- Hold down **DISTRESS KEY** for 5 seconds as confirmation.
- An acoustic alert sign will emit(70CH)and the distress call will be carried out.
- While the screen displays "WAIT FOR ACK KEEP PRESS16 TO CANNEL"
- Click the 16 keys, LCD display "CANNEL DISTRSEE" while 70 channels transmit a reply message, the alarm sound disappeared, returned 16 channel display.
- If the distress call is received and confirmed by another station, the alert sign will stop and the display will return to normal use in VHF model on channel 16 (70CH sending on high transmission power.)
- If no confirmation is received,the unit will send again the distress call at intermission of 4 minutes (even with channel 70 in use) until a confirmation is received .
- User manually cancel the call through press 16 (distress cancell) buttons or PTT With the UP/DOWN keys scroll through the digits and insert UTC

8.8 Position Request

It is possible to send a DSC call to requie the position of a DSC station (it may be preset in the directory or manually inserted).

- Hold down the **MENU/SELECT** key till the display indicates **DSC CALL**
- Press **MENU/SELECT** as confirmation
- Scroll through the channels with the **UP/DOWN** keys
- Select **POS REQUEST** and confirm by pushing **MENU/SELECT**
- You will be asked a MMSI code, which may be manually inserted or found in the directory
- Select **MANUAL INPUT** or **DIRECTORY** with the **UP/DOWN** keys
- Insert the code with the **UP/DOWN** keys (in case of manual selection) and press **MENU/SELECT** as confirmation

The request will be sent to the selected DSC station and the display will show **WAITING ACK**.

8.9 STAND BY option

Every time a DSC call is received, you can manually choose whether accept or refuse it.

If you activate the Stand By option, the radio will automatically refuse the incoming calls (individual, group call, all ship safety, position request)

- Hold down MENU/SELECT till DSC CALL appears on the display
- Press again MENU/SELECT as confirmation
- With the UP/DOWN keys, select STAND BY, and confirm with MENU/SELECT.
- Select ON if you want to refuse automatically the incoming calls
- Select OFF to manually answer to incoming calls.
- Confirm by pushing the MENU/SELECT button.

To return to the radio mode, push PTT, select EXIT in any menu or wait for 1 minute and the radio will automatically exit.

9. RECEIVING A DSC CALL

When the user receives a DSC call, the transceiver will automatically respond according to the type of call.

Information shown on the LCD display will vary according to the type of call.

9.1 Receiving a individual call

- When the transceiver receives an individual call, it automatically move to the channel indicated by the DSC signal and emits a tone to alert the user of an incoming call.
- LCD Display scrolls "INDIVIDUAL ROUTINE FROM 888888888 (MMSI) ON CHANNEL 6(OTP)"
- The pressure to the function key MENU/SELECT will deactivate the alarm and display While the other replies CALL
- EXIT press 16 to exit or PTT.
- The MMSI owner code contained in the signal appears on the display.

When you hear the alarm sound, with UP / DOWN keys to select "DISABLE ACK" and "ENABLE ACK" If you select ENABLE, Press MENU / SELECT confirm, transmitting a return signal to the caller, the device automatically go to work can be normal call channels (channels with the other settings), if you choose DISABLE, Press MENU/SELECT confirm, the device automatically go to the original work can be normal call channel.

If the MMSI owner code has been programmed previously with name in the directory, the name of the caller appears too.

Every time KV-300 receives a individual call an entry will be stored in the list of registered calls "LOG".

9.2 Receiving a Group call

- When the transceiver receives a GROUP call ,an acoustic alaem will sound, the LCD displays "GROUP CALL FROM MMSI ON CHANNEL 6(OTP)
- The pressure to the function key MENU/SELECT will deactivate the alarm and display
- The display will jump to the corresponding channel
- After receiving the alarm ,EXIT press 16 to exit or PTT
- Every time KV-300 receives a GROUP call an entry will be stored in the list of registered calls "LOG".

9.3 Receiving a General call to all ships (ALL SHIP SAFETY- ALL SHIP URGENCY)

- When the transceiver receives a ALL SHIP SAFETY and ALL SHIP URGENCY, an acoustic alarm will sound, and the LCD displays "ALL SHIP SAFETY FROM MMSI or ALL SHIP URGENCY From MMSI"
- The pressure to the function key MENU/SELECT will deactivate the alarm and display
- Safety call to set the display will jump to the other side channels, Urgency call display will jump to 16 channels
- After receiving the alarm,EXIT Press 16 or PTT
- Every time KV-300 receives a General call to all ships(ALL SHIP SAFETY- ALL SHIP URGENCY) call an entry will be stored in the list of registered calls "LOG".

9.4 Receiving a distress call

- When the transceiver receives a distress call, an acoustic alarm will sound.
- LCD scrolls "DISTRESS MESSAGE FROM 888888888 (MMSI)"
- The pressure to the function key MENU/SELECT will deactivate the alarm.
- Press UP/DOWN key to view DISTRESS information if the other party to cancel the DISTRESS, LCD displays "DISTRESS CANCEL ALERT FROM MMSI"
- Every time KV-300 receives a Distress call an entry will be stored in the list of registered calls "LOG".

When the signal also includes position and time data, these information will appear on the display.

If no position and time data are included in the signal, the display will indicate 99°99 999°99 88:88.

10. CUSTOMIZATION

10.1 "Log" (list of registered calls)

With this menu you can consult a directory of the latest registered incoming calls, like you do with your cellular phone.

- Hold down **MENU/SELECT** till the display shows **DSC CALL**
- Push **MENU/SELECT** as confirmation
- Select **LOG**, with the **UP/DOWN** keys and confirm pushing **MENU/SELECT** again

Now you can see the list of the latest incoming calls.

To get further information select the desired message by pushing **MENU/SELECT**; coordinates, time and sender ID will be shown.

In radio mode, the display indicates **LOG**

When it's fixed, indicates that some messages are present in the register of the latest calls; if it blinks, indicates that there are some messages which have not been read yet.

10.2 "Dir" (Entries in the directory)

You can insert into the directory the MMSI codes from frequently called stations, by giving them a name (e.g. vessel or owner). Then you can search and use them more comfortably. When receiving a call, the MMSI owner name instead of the MMSI code will be displayed.

To add new MMSI codes follow this procedure:

- Hold down **MENU/SELECT** till **DSC CALL** is displayed
- Select **SET UP** with the **UP/DOWN** keys and confirm by pushing **MENU/SELECT** again
- Select **DIR** with the **UP/DOWN** keys and push **MENU/SELECT** as confirmation
- With the **UP/DOWN** buttons, select: **NEW** for new addresses and **DELETE ALL** to cancel all of them.

If you push again the **UP/DOWN** buttons you will see the addresses previously stored.

Confirm the function you want to select (**NEW - DELETE ALL**)

Scroll the **UP/DOWN** keys to insert a new name.

Hold down **MENU/SELECT** to insert the ID identifier code.

To return to radio mode, push **PTT**, select **EXIT** in every menu or wait for 1 second and the radio will automatically exit.

To modify some addresses repeat the above described procedure till the display shows the address to change. Now press **MENU/SELECT**.

Select **EDIT** to change the name or code.

Select **DELETE** to cancel that address.

You can store up to 16 addresses. If the directory is filled up, " Full " will appear on the display, you cannot add further addresses. In this case it is necessary to cancel some.

10.3 GPS

Coordinates (latitude and longitude) can be manually inserted without any connection to a GPS antenna. Follow these steps:

- Keep pressed **MENU/SELECT** until the display indicates *DSC CALL*
- Scroll through the functions and select **GPS**; Confirm with the **MENU/SELECT** button
- Latitude and longitude may be modified by pushing **MENU/SELECT** and scrolling the digits with **UP/DOWN**
- UTC (Universal Time Coordinate) Tempo Universale Coordinato) may be modified by pushing **MENU/SELECT** and scrolling the digits with **UP/DOWN**
- Confirm by pushing **MENU/SELECT**

With the UP/DOWN keys scroll through the digits and insert UTC

To return to radio mode, press **PTT**, select **EXIT** which is present in every menu or wait for 1 minute and the radio will automatically exit.

For a better efficiency of the DSC service, we suggest you insert coordinates and time. If **KV-300** is connected to a compatible GPS receiver Module, the setting of these data is not compulsory.

10.4 GPS SELECT

KV-300 is compatible with almost all the GPS receivers available on the market. Verify the compatibility with your receiver.

GPS receivers use different strings; in the **KV-300** menu you can enable/disable many types of strings.

According to your needs, select the desired string following this procedure:

- Hold down **MENU/SELECT** until **DSC CALL** appears on the display
- Scroll the list of functions with the **UP/DOWN** keys
- Select **GPS SELECT** and confirm by pushing **MENU/SELECT**

Strings are all active by default, therefore you have to disable the undesired ones.

Select it with **UP/DOWN** keys and confirm by pushing **MENU/SELECT**.

Select **ON** or **OFF** and confirm.

Data Input Format(GPGGR,GPRMC,GPGNS,GPGLL)

To return to radio mode, push **PTT**, select **EXIT** in every menu or wait for 1 Minute and the radio will automatically exit.

10.5 " Beep " (Enable/disable keypad beep)

Everytime a button is pressed, the radio emits a signal as confirmation or to warn about wrong operations.

To disable these beeps, follow this procedure:

- Hold down **MENU/SELECT** until **DSC CALL** appears on the display
- Scroll the list of functions with the **UP/DOWN** keys
- Select **SYSTEM** and confirm by pushing **MENU/SELECT**
- Scroll the list of functions with the **UP/DOWN** keys
- Select **KEY BEEP** and confirm by pushing **MENU/SELECT**

if this function is active, on the display **ON** will appear; while if it's disabled, the display will show **OFF**. Select the desired setting.

To return to radio mode, push **PTT**, select **EXIT** in every menu or wait for 1 second and the radio will automatically exit.

10.6 Display/keypad backlight.

According to the environmental conditions you can adjust the display/keypad backlight.

- Hold down **MENU/SELECT** until **DSC CALL** appears on the display
- Scroll the list of functions with the **UP/DOWN** keys
- Select **SYSTEM** and push **MENU/SELECT** as confirmation
- Scroll again the list of functions with the **UP/DOWN** keys
- Select **BACK LIGHT** and confirm by pushing **MENU/SELECT**.
- Choose the desired backlight level (from 0 to 3).

To return to radio mode, push **PTT**, select **EXIT** in every menu or wait for 1 minute and the radio will automatically exit.

10.7 Band Edit

This function may be activated only with the optional programming kit PRG KV-300.

It allows the selection of the following bands:

USA-CANADA-INTERNATIONAL (default)

- Hold down **MENU/SELECT** until **DSC CALL** appears on the display
- Scroll the list of functions with the **UP/DOWN** keys
- Select **SYSTEM** and push **MENU/SELECT** as confirmation
- Select **BAND EDIT** and push **MENU/SELECT** as confirmation
- Scroll the list of functions with the **UP/DOWN** keys
- Set up: **BAND: USA-CANADA-INTERNATIONAL (default)**

10.8 LCD contrast

The user can adjust the display contrast to optimise visibility according to ambient conditions. To change this setting:

- Hold down MENU/SELECT until DSC CALL appears on the display
- Scroll the list of functions with the UP/DOWN keys
- Select SYSTEM and confirm by pushing MENU/SELECT
- Scroll again the list of functions with the UP/DOWN keys
- Select LCD Adjust and push MENU/SELECT as confirmation
- Choose the desired level, from 0 to 7.

To return to radio mode, push PTT, select EXIT in every menu or wait for 1 Minute and the radio will automatically exit.

10.9 MMSI (Setting of personal MMSI code and MMSI group code)

This function allows the user to insert their personal MMSI identification code assigned by an appropriate authority.

Be careful to insert the correct personal MMSI code. Once the code has been saved, it cannot be modified.

- Hold down MENU/SELECT until DSC CALL appears on the display
- Scroll the list of functions with the UP/DOWN keys
- Select SET UP and confirm by pushing MENU/SELECT. MMSI will be displayed.
- Scroll the alphanumerical list with the UP/DOWN keys and digit your own *MMSI* code.

Follow the same procedure to insert the MMSI group code but select **GROUP MMSI** instead of your own MMSI code.

- Hold down MENU/SELECT until DSC CALL appears on the display
- Scroll the list of functions with the UP/DOWN keys
- Select SET UP and confirm by pushing MENU/SELECT. MMSI will be displayed.
- Scroll the alphanumerical list with the UP/DOWN keys and digit your **GROUP MMSI** code.

It is possible to change the MMSI group code whenever you want, while the personal MMSI code can be inserted only one time; for this reason, we recommend to pay attention.

If you have accidentally inserted an incorrect code, you will have to return the device to your approved vendor for a complete reset.

10.10 " ATIS " (Setting of ATIS code and activation deactivation of automatic transmission)

Your marine transceiver is able to activate, if necessary, an automatic transmission of your ATIS identification code each time the PTT is released. This function is only used when navigating in internal navigable European waters which require automatic transmission of identification.

The user can request an ATIS code from the same authority which releases the radio operators licenses.

- Hold down MENU/SELECT until DSC CALL appears on the display
- Scroll the list of functions with the UP/DOWN keys
- Select SET UP and confirm by pushing MENU/SELECT. MMSI will be displayed
- Scroll the list of functions with the UP/DOWN keys
- Select ATIS MMSI and confirm by pushing MENU/SELECT.
- You can now enter the ATIS MMSI code. After the final digit is entered, press MENU/SELECT, the radio displayed Scroll "Press select Button to confirm MMSI"
- pushing MENU/SELECT. MMSI will be display "ATIS MMSI"
- Pushing MENU/SELECT will confirmed.

The ATIS MMSI code may be enabled or disabled according to your needs.

Following:

- Hold down MENU/SELECT until DSC CALL appears on the display
- Scroll the list of functions with the UP/DOWN keys
- Select SET UP and confirm by pushing MENU/SELECT. MMSI will be displayed
- Scroll the list of functions with the UP/DOWN keys
- Select ATIS MMSI and confirm by pushing MENU/SELECT
- Select ATIS ON/OFF Scroll the list of functions with the UP/DOWN keys
- Pushing MENU/SELECT confirm. Choose ON or OFF, Press MENU/SELECT confirm.

If regulations in your community do not allow you programming the ATIS code by yourself, contact your approved vendor for programming.

Activate the ATIS code only when requested by the proper authorities.

We remind you that when the ATIS function is activated, DSC call are disabled.

11. Programming and selection of private channels

Only authorized customers are allowed to use private channels. For detailed information contact your local radio communications authorities. To program the private channels, it is necessary to connect the programming kit “PRG-KV-300” (optional), otherwise ask your approved vendor.

- Once have been programmed private channels (maximum 20), they can be selected with the UP/DOWN keys.
- Like all other channels in use, the private channels can be merged with all the functions described previously (Dual watch, Triple watch, Memory Scan etc.)

12. MAINTENANCE

12.1 Maintenance and warnings

KV-300 is a marine VHF transceiver that conforms to IPX7 standard, making the transceiver very reliable when used correctly.

The device was designed so as to avoid requiring maintenance. To keep your transceiver in optimal operating conditions:

Never open the device (transceiver or microphone) as this may compromise the water resistant seal.

If the device becomes dirty or dusty, do not use alcohol, solvents or abrasives to clean it. Use only a soft cloth, slightly dampened with water. For more persistent cases, use a mild detergent.

13. TROUBLESHOOTING

Problem	Possible causes	Solution	Ref
Device doesn't turn on	Power supply is not correctly connected	Power supply is not correctly connected	4.7 a
Device turns on, but doesn't receive signals	Antenna is not correctly connected	Verify that antenna is properly connected	4.7 c
	Volume level is too low	Adjust volume level	5.2
	Squelch level is too high	Adjust squelch level	5.3
Unable to contact another party	Incorrect marine channel selected	Verify channel and, if necessary, change channel	5.4
Other party has difficulty in hearing you	Distance is too far and low transmission power (LO) was accidentally selected	Select high transmission power (HI)	5.6
Reception is broken and/or disturbed	Squelch level is too high	Adjust squelch level	5.3
	Signal is too weak (other party is too far away and/or antenna is blocked by obstacles)	Try to completely open the squelch and/or move closer to the other party	5.3
	Other users are using the same radio channel	Verify radio traffic on desired channel and, if necessary, change channel	5.4
	Other interference devices (televisions, computers, transceivers, etc.) too close to KV-300	Move other interference devices further from KV-300	-
Impossible to transmit or use high transmission power	Some channels operate only on low power or are only for reception	Tune to another channel	5.4
DSC, MMSI or ATIS functions unusable	Individual MMSI and/or ATIS codes have not been programmed	Program the codes	10.9 10.10
Vessel battery runs down sooner than expected	Excessive use of transmission	Vessel battery runs down sooner than expected	5.6
Scanning and/or Dual/Triple Watch malfunctioning	Squelch has not been correctly adjusted	Adjust squelch level	5.3

14. TECHNICAL SPECIFICATIONS

Channels	All 57 international marine channels
Frequency generation	PLL synthesizer
Frequency range	TX from 156.025 to 157.425 MHz RX from 156.300 to 162.000 MHz
Antenna Impedance	50 Ohm
Power supply	12 Vdc
Operating temperature	from -15°C to +55°C
Duty cycle	5/5/90
Size	70mm×75mm×148mm
Weight (device only)	1.380 Kg

14.1 Transmitter

- Output power High (HI): 25W/Low (LO):1W
- Modulation Type FM
- Type of emission 16K0G3E(VOICE) 13K5G2B(DSC)
- Microphone condenser type
- Audio Frequency Response deviation 6dB/octave emphasis characteristics +/-3dB range (300HZ-3K)
- Frequency Deviation 5KHZ Max
- Hum and noise attenuation 34dB
- Audio distortion < 5%
- Harmonics reduction < 36dBm
- Spurious radiation <0.25UW
- Current <5Amps(25W)

14.2 Receiver(Multi-channe)

- Dual conversion superheterodyne receiver design
- IF frequency 21.4MHZ, 455KHZ
- Audio Frequency Response: deviation 6dB/octave emphasis characteristics +/-3dB range (300HZ-3K)
- Spurious radiation <0.25nw
- Sensitivity @ 20 dB Sinad <0.5 μ V.
- S/N ratio (20dB) <0.8 μ V
- Squelch sensitivity Threshold -12dB μ V (EMF)
- Adjacent channel rejection 70dB

- Adjacent channel selection.....>70dB
- Audio output power.....>2W 8 Ohm
- Audio distortion.....<5%
- Current.....<0.9Amps(Max Audio) <0.4Amps(STBY)

14.3 70 channel receiver

- Frequency.....CH70 (156.525MHZ)
- Sensitivity @ 20 dB Sinad.....<0.5 μ V.
- IF frequency.....17.9MHZ, 455KHZ
- Adjacent channel selection.....>70dB
- Modulation Type.....16K0G2B
- Spurious radiation.....<2nw,9K to 2GHZ

14.4 GPS

- Data Input Format.....NMEA0183 VER:2.0:
GPGGR,GPRMC,GPGNS,GPGLL

According to: ITU-R standard, M493-11 Class D requirement the design

15. FREQUENCY TABLE

INTERNATIONAL (INT)				
CH	Frequency (MHz)			
	TX	RX	Mode	Note
01	156.050	160.650	D	
02	156.100	160.700	D	
03	156.150	160.750	D	
04	156.200	160.800	D	
05	156.250	160.850	D	
06	156.300	156.300	D	
07	156.350	160.950	D	
08	156.400	156.400	S	
09	156.450	156.450	S	
10	156.500	156.500	S	
11	156.550	156.550	S	
12	156.600	156.600	S	
13	156.650	156.650	S	
14	156.700	156.750	S	
15	156.750	156.750	S	
16	156.800	156.800	S	
17	156.850	156.850	S	
18	156.900	161.500	D	
19	156.950	161.550	D	
20	157.000	161.600	D	
21	157.050	161.650	D	
22	157.100	161.700	D	
23	157.150	161.750	D	
24	157.200	161.800	D	
25	157.250	161.850	D	
26	157.300	161.900	D	
27	157.350	161.950	D	
28	157.400	162.000	D	
60	156.025	160.625	D	

INTERNATIONAL (INT)				
CH	Frequency (MHz)			
	TX	RX	Mode	Note
61	156.075	160.675	D	
62	156.125	160.725	D	
63	156.175	160.775	D	
64	156.225	160.825	D	
65	156.275	160.875	D	
66	156.325	160.925	D	
67	156.375	156.375	S	
68	156.425	156.425	S	
69	156.475	156.475	S	
70	156.525	156.525	S	
71	156.575	156.575	S	
72	156.625	156.625	S	
73	156.675	156.075	S	
74	156.725	156.125	S	
75	156.775	156.175	S	
76	156.825	156.225	S	
77	156.875	156.275	S	
78	156.925	161.525	D	
79	156.975	161.575	D	
80	157.025	161.625	D	
81	157.075	161.675	D	
82	157.125	161.725	D	
83	157.175	161.775	D	
84	157.225	161.825	D	
85	157.275	161.875	D	
86	157.325	161.925	D	
87	157.375	157.375	D	
88	157.425	157.425	D	

S= Simplex

D= Duplex

*= obligatory low transmission power of 1 Watt

**= classified to DSC communications

